



UNDERGROUND DEWATERING PUMPS BY DYNAPUMPS



Our mining experience in underground dewatering guarantee results

The mining industry makes extraordinary demands on equipment due to the often hostile and remote environments in which it operates. The pumps used in mining are no exception to this rule and accordingly Dynapumps only offer the very best and most durable machines available. Our team of global partners offer quality in both product and support. We are renowned for superior quality and reliability in underground mining equipment. Dynapumps mine dewatering pumps are used by leading mining companies who value premium quality and performance.

Our systems are specifically designed and engineered to work in the highly abrasive and corrosive applications associated with high pressure mine dewatering. We aim to help you achieve your goals and objectives with high quality products and reliable pump equipment.

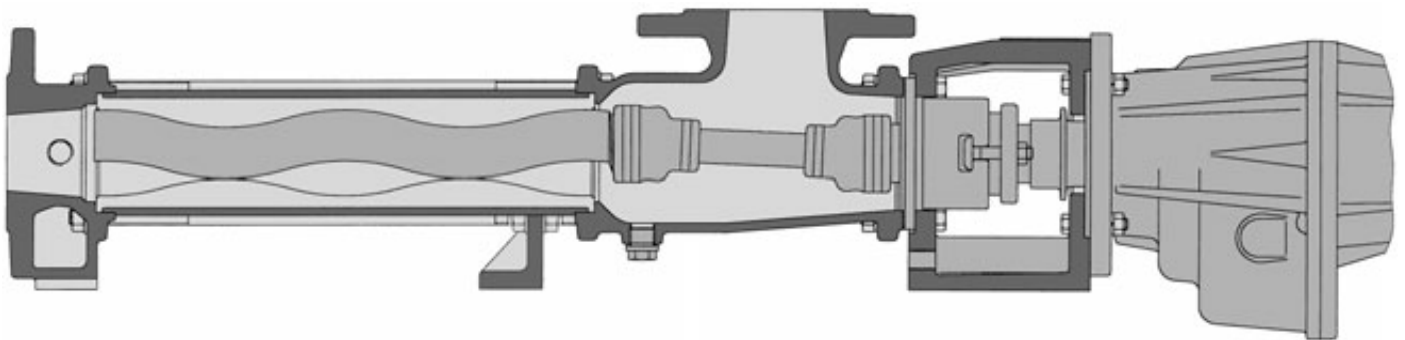

Utilising the best in progressive cavity pump technology

We use innovative solutions for pumping low-viscous to highly viscous media with or without solids.

- Drive casing with free shaft end facilitates universal configuration of drives through flexible couplings or V-belts
- Drive shaft bearing implemented through relubricatable taper roller bearings
- Conveying capacities: 0.132 GPM - 2,200 GPM
- Pressures: up to 720 PSI

System design and consultative approach

Our engineering and design capabilities are a unique combination of open-cut and underground mine pump equipment partnered with technical expertise and extensive experience. Once the system is complete, we perform full functional testing to ensure you are happy with the job.

Our team is composed of highly trained professionals and technical engineers who are experts in their fields with extraordinary track records in the design and delivery of infrastructure projects. We adopt leading practice and the latest software to provide our customers with a range of services, from studies and front end design engineering, through to detailed design.

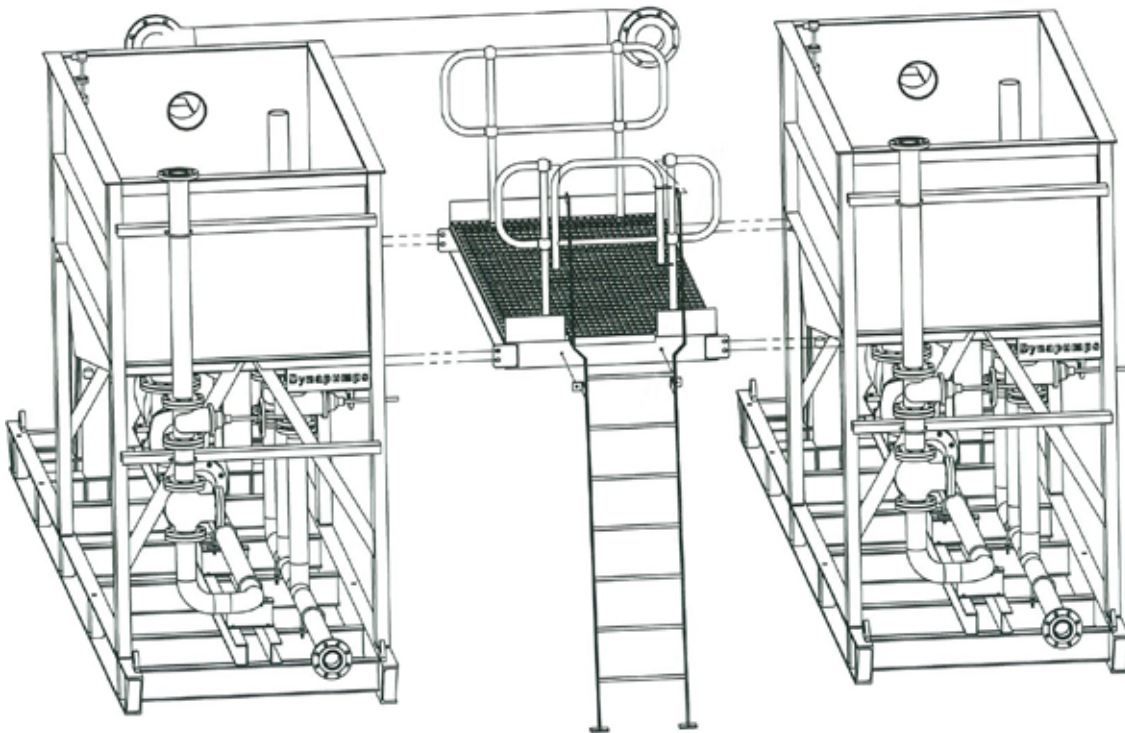

Ladders, walkways and access are all built to comply with Australian Standard AS1657

Locally manufactured, lifetime maintenance

The pump skids are manufactured with a 'A Frame' hoist supplied for pump maintenance and repair capabilities. The pump bases are modularly designed to facilitate interchangeable components, full bases and pump duty flow.

Also included a comprehensive backup program offering local and onsite maintenance, local repairs and allocated parts from trusted suppliers.





AUSTRALIA WIDE

Perth - Head Office

88 Belgravia Street,
Belmont, WA 6104

Sydney

Unit 5 / 6 Stanton Road,
Seven Hills, NSW 2147

Brisbane

Unit 7/ 14 Hopper Avenue
Ormeau, QLD 4208

Melbourne

Unit 5/39 Heyington Avenue
Thomastown, VIC 3074