

Agilent IDP-3 Dry Scroll Vacuum Pump

Data Sheet

The Agilent IDP-3 dry scroll pump is an innovative, compact, high-performance, oil-free vacuum pump that is suitable for a wide variety of applications. It is the smallest scroll pump made for general vacuum applications, which makes it easy to integrate into OEM systems, and it weighs only 21 pounds (9.5 kg). Yet with a pumping speed of 60 L/min and a very low base pressure of 250 milliTorr, it is the highest-performing dry pump in its class.



Technical specifications

IDP-3 dry scroll single sided hermetic vacuum pump

Peak pumping speed	60 Hz/24 VDC: 60 L/min (3.6 m ³ /h) 50 Hz: 50 L/min (3.0 m ³ /h)
Media	No corrosive, explosive or particulate forming gases
Ultimate pressure	3.3 x 10 ⁻¹ mbar (2.5 x 10 ⁻¹ Torr)
Max. inlet pressure	1.0 atmosphere (0 psig)
Max. outlet pressure at nom voltage	1.4 atmosphere (6.5 psig)
Inlet connection	NW16
Exhaust connection	Female, 0.25 inch, national pipe thread (10 mm hose barb provided installed)
Gas ballast	Female, 0.25 inch, national pipe thread (shipped with gas ballast port plug installed; 20 µm sintered filter provided)
Ambient operating temperature	5 to 40 °C (41 to 104 °F)
Storage temperature	-20 to 60 °C (-4 to 140 °F)
Motor rating	0.16 HP (120 W)
Operating voltages	100-120; 200-240 VAC, 50/60 Hz, single phase, 3 to 6A typical
Motor thermal protection	Automatic thermal protection
Operating speed	60 Hz/24 VDC: 3200 rpm 50 Hz: 2600 rpm
Cooling system	Air-cooled
Weight	Pump only: 9.5 kg (21 lbs), shipping weight: 10.5 kg (23 lbs)
Dimensions (H x W x L mm)	181 x 140 x 358
Leak rate (with exhaust sealed)	<1 x 10 ⁻⁶ sccs helium (1 x 10 ⁻⁶ mbar.l/s)
Noise level	55 dB (A)
Vibration level at inlet	5 mms ⁻¹ rms
Hour meter	Integral hour meter provided
Emissions and immunity	EN 61236-1:2013 as a Class A device
Safety	EN/IEC 61010 3rd Edition certified

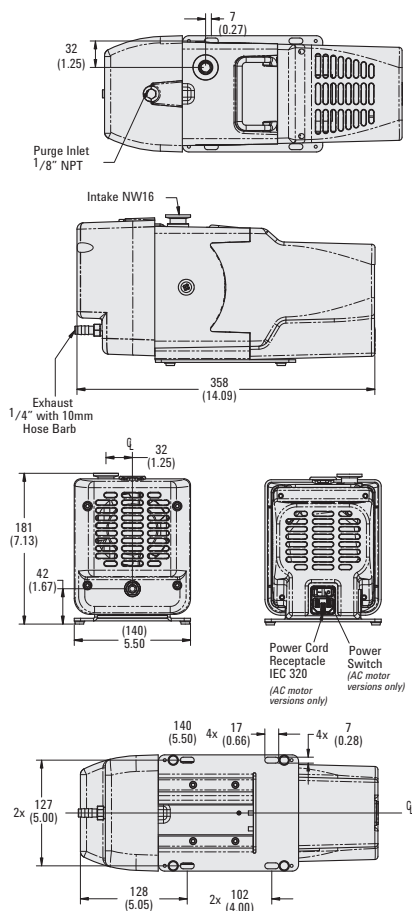

Dimensions: millimeters [inches]



Ordering information

IDP-3 dry scroll pumps and accessories

Description	Part number
IDP-3, 1 ϕ , 220 V, 50/60 Hz	IDP3A01
IDP-3, 1 ϕ , 115 V, 60 Hz	IDP3B01
IDP-3, 1 ϕ , 100 V, 50/60 Hz	IDP3C01
IDP-3, 24 VDC	IDP3D01
With inlet isolation valve	
IDP-3, 1 ϕ , 220 V, 50/60 Hz	IDP3A21
IDP-3, 1 ϕ , 115 V, 60 Hz	IDP3B21
IDP-3, 1 ϕ , 100 V, 50/60 Hz	IDP3C21
IDP-3, 24 VDC	IDP3D21
Service parts	
IDP-3 tip seal replacement kit	IDP3TS
Accessory parts	
Exhaust silencer kit	EXSLRIDP3
Inlet trap	SCRINTRPNW16
Vibration Isolation Kit	IDP3VIBISOKIT

Power cords for IDP-3 AC motor, IDP-7, IDP-10, and IDP-15 vacuum pumps

Description	Part number
Europe, 10 A/220-230 V, 2.5 m	656494220
Denmark, 10 A/220-230 V, 2.5 m	656494225
Switzerland, 10 A/230 V, 2.5 m	656494235
UK/Ireland, 13 A/230 V, 2.5 m	656494250
India, 10 A/220-250 V, 2.5 m	656494245
Israel, 10 A/220-230 V, 2.5 m	656494230
Japan, 12 A/100 V, 2.3 m	656494240
North America, 15 A/125 V, 2.0 m	656458203
North America, 10 A/230 V, 2.5 m	656494255

